



Volume XVII Issue 3  
 Editor: Howard; KC2OJO

March 2010

## IMPORTANT NOTICE

**Last Chance to pay your dues and receive all of the benefits of being a Larkfield ARC member. Your dues are used for the continued operation and upkeep of our repeaters, our newsletter, Field Day activities, demonstrations and the monthly meetings and holiday party where we all share camaraderie, friendship and a common love for the art of radio communications. Fill in the form on page 3 and mail today.**

### Minutes of the February 11th Meeting

The meeting started with 16 member introductions (a quorum) at 7:50 PM, immediately following the end of the Board Meeting. Board members and officers present were Chuck N2JIY, Ed KC2E, Fred K2LDC, Roger W2GLE, Danny KC2TFS, Pat WS2A and Howard KC2OJO.

Roger W2GLE gave the Treasurer's report but the Secretary's Reading of the minutes was waived as they had previously appeared in QSX.

Howard KC2OJO gave the QSX and Larkfield Web Site report stating that the Feb QSX had gone out electronically on January 27th and been sent out by mail by Richard KA2LHK shortly afterwards. He also told the club that the web site had been down for a day late in January due a problem at our web site provider.

Field day and the Field day Committee will be run by two volunteers, Pat WS2A and Fred K2LDC; both of whom volunteered to stay overnight on Field Day.

Bruno gave the Repeater report. He said that he will probably use the club's MSF-2000 controller at the

Boxer Court site (147.210)but will also evaluate potential use of the MSF-5000. He also reported that Richard WA2WNY was making progress on bring up the Dix Hills repeater (145.075).

Larry N2BKJ gave the membership report and submitted two new members to the club. Scott KC2OZ and Martin W2NTS were voted into the club.

Ed KC2E gave the VE report and announced that there would be a VE session on the following Saturday.

Howard KC2OJO gave the Day Timers and Night Timers reports – both weekly scheduled meetings are ongoing.

The meeting was adjourned at 8:20 PM.

### The K7RA Solar Update

We've now observed sunspots continuously for the past 30 days -- certainly a turnaround from the quiet conditions of the past few years. In fact, in 10 weeks, we have seen only three days with no sunspots: December 25, January 6 and January 19. This is a little more than 4 percent no-sunspot days, a nice contrast with all of 2009,

Continued on page 2

Continued from page 1

with more than 71 percent days with no sunspots. Sunspot numbers for February 11-17 were 64, 38, 37, 28, 27, 28 and 49, with a mean of 38.7. The 10.7 cm flux was 94.2, 95.5, 94.1, 89.4, 87.6, 86.8 and 86.9, with a mean of 90.6. The estimated planetary A indices were 5, 6, 3, 4, 14, 9 and 4, with a mean of 6.4. The estimated mid-latitude A indices were 4, 4, 2, 3, 8, 11 and 2 with a mean of 4.9. Since the first of the year, the average weekly sunspot numbers were 14.6, 26.4, 18.6, 28, 14.6, 43.3 and 38.7. Sunspot group 1049 emerged on Wednesday -- and it is growing! The minimum non-zero sunspot number is 11. This is because the numbers are derived from the number of sunspot groups, plus areas inside the groups. Each group counts for 10, so the minimum sunspot number is 11 and the minimum sunspot number for at least two sunspot groups is 22. In 2009, only 87 days (23.8 percent) had sunspot numbers greater than 11; 21 of those days were in December. Only 43 days (11.8 percent) had a sunspot number greater than 15 (14 of those in December) and only 26 days in 2009 had a sunspot number of 23 or more (none had 22). Courtesy of ARRL

## February 11th Executive Board Meeting

Board members and officers present were Chuck N2JIY, Ed KC2E, Fred K2LDC, Roger W2GLE, Danny KC2TFS, Pat WS2A and Howard KC2OJO. The meeting started at 7:15 PM and ended at 7:50 PM.

Two topics were brought to the Larkfield Board's attention: 1) Whether to formally merge with Huntington ARES and therefore hold the ARES meetings during the Larkfield General meetings and 2) Whether the Larkfield policy would be to remove non-dues-paying members from the Reflector during the month of March..

After discussion, the Larkfield ARC Board voted to not merge with Huntington ARES at the present time. It was also decided that non-dues-paying members would be removed from the reflector in March.

*The following is a great chapter on Neutralization from the book "Basic Radio" by J.B. Hoag, 1942, taken from the VIAS website. See [www.vias.org](http://www.vias.org). Many thanks to Bruno KC2ESI for spotting the science treasure trove established by the Virtual Institute of Applied Science.*

Amplifier circuits tend to oscillate because of the feedback through the inter-electrode capacitances of the tube itself, because of the electrostatic and electromagnetic feedback external to the tube, and because of improper connections whereby currents of the input and output circuits flow through a common wire or through a portion of the shields from one grounded point to another. This is particularly true of radio frequency amplifiers which have tuned-grid and tuned-plate circuits. The feedback through the tube itself is largely alleviated by using tetrodes and pentodes, with condensers (C2 of Fig. 27 E) shunting r.f. currents directly to ground from the screen and suppressor grids.

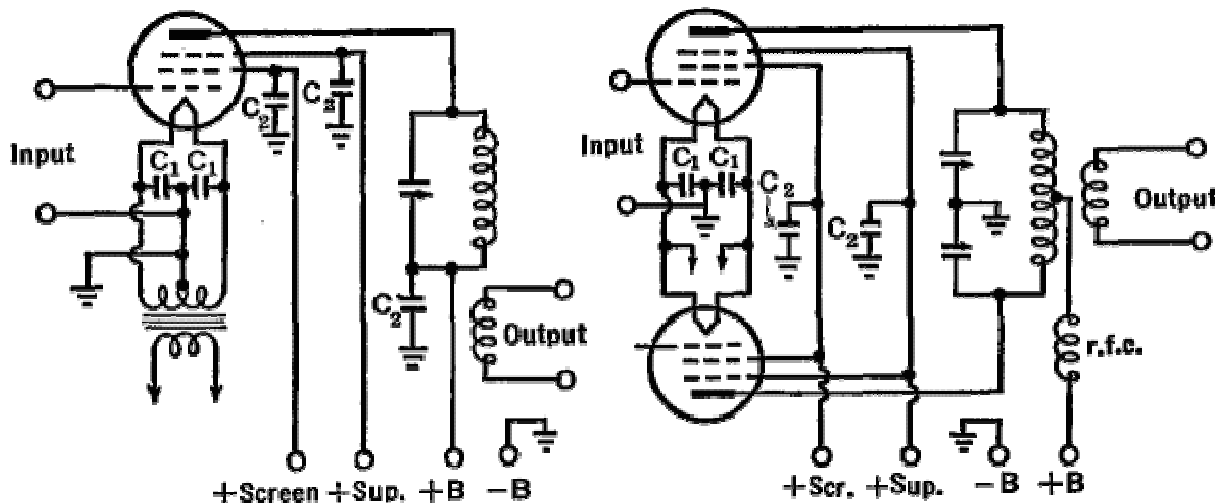

Fig. 27 E. R.F. amplifier circuits. C1 = 0.01 $\mu$ fd. C2 = 0.001  $\mu$ fd. or more Continued on page 3

Even so, certain of these tubes (6L6, 6V6, 6F6, and the like), designed for audio frequency use, do not have sufficient screening for use as r.f. amplifiers unless additional precautions are taken. Many of the tubes designed for handling large amounts of power, as in the amplifier stages of transmitters, are merely triodes. For these, it is imperative that "neutralization" circuits be used to prevent oscillation.

Neutralization consists of feeding some of the r.f. voltages from the output or from the input of the amplifier to the other side in such a manner as to cancel the r.f. voltage developed through the grid-to-plate capacitance of the tube itself. There are three main methods, called plate, grid, and inductive neutralization.

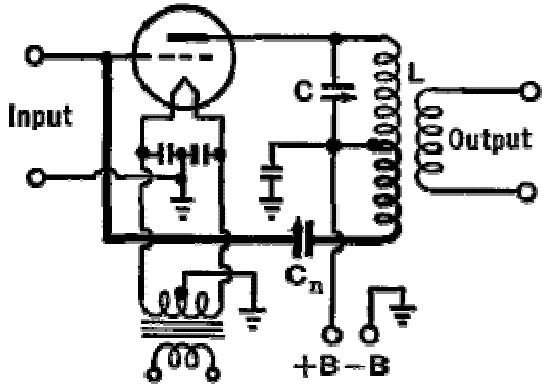

Fig. 27 F. A plate-neutralized r.f. amplifier circuit

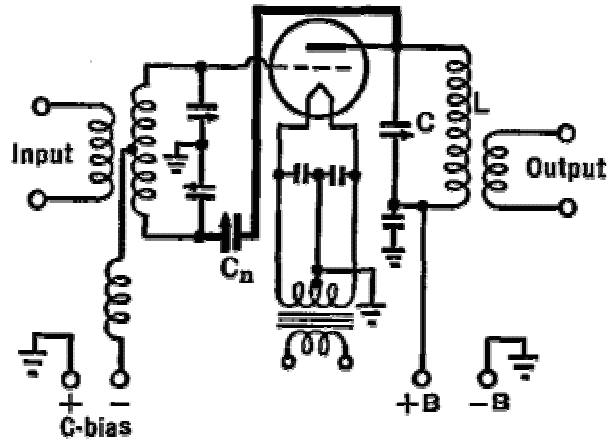

Fig. 27 G. A grid-neutralized r.f. amplifier circuit

Continued on page 6

**2010 Dues Schedule**

Regular Membership \_\_\_\_\_ \$25.00/Yr    Senior Membership (Over 65) \_\_\_\_\_ \$18.75/Yr

Youth Membership 21 or less and Student \_\_\_\_\_ \$12.50/Yr

Outside of Repeater Coverage Area \_\_\_\_\_ \$6.25/Yr

Family Membership (2<sup>nd</sup> or 3<sup>rd</sup>, etc.) \_\_\_\_\_ \$6.25/Yr

Name \_\_\_\_\_ Call Sign \_\_\_\_\_

Email Address \_\_\_\_\_

Membership Type: Reg    Sr.    Youth    Family    Outside    Chosen

Choose Amount    \$25.00    \$18.75    \$12.50    \$6.25    \$6.25    \_\_\_\_\_

\$5.00 Additional for OSX Mailing? \_\_\_\_\_

Total \_\_\_\_\_

Please complete form, make out check to Treasurer L.A.R.C. , and bring to January 14th meeting or mail to:

Larkfield amateur Radio Club  
 Post Office Box 1450  
 Huntington, NY 11743

# The Amateur Radio Crossword Puzzler

## *Weather Or Not*

By H. Ward Silver, N0AX  
December 22, 2006

All of our fancy radio and electronic equipment depends on detailed knowledge of the behavior of matter at the smallest of scales. Here is where ICs acquire their characteristics and where memories are stored. At this scale, quantum mechanics takes over! This week's puzzle shrinks its focus down to the level where the world is mostly empty space--the atomic--so your pencil will have to be mighty sharp.

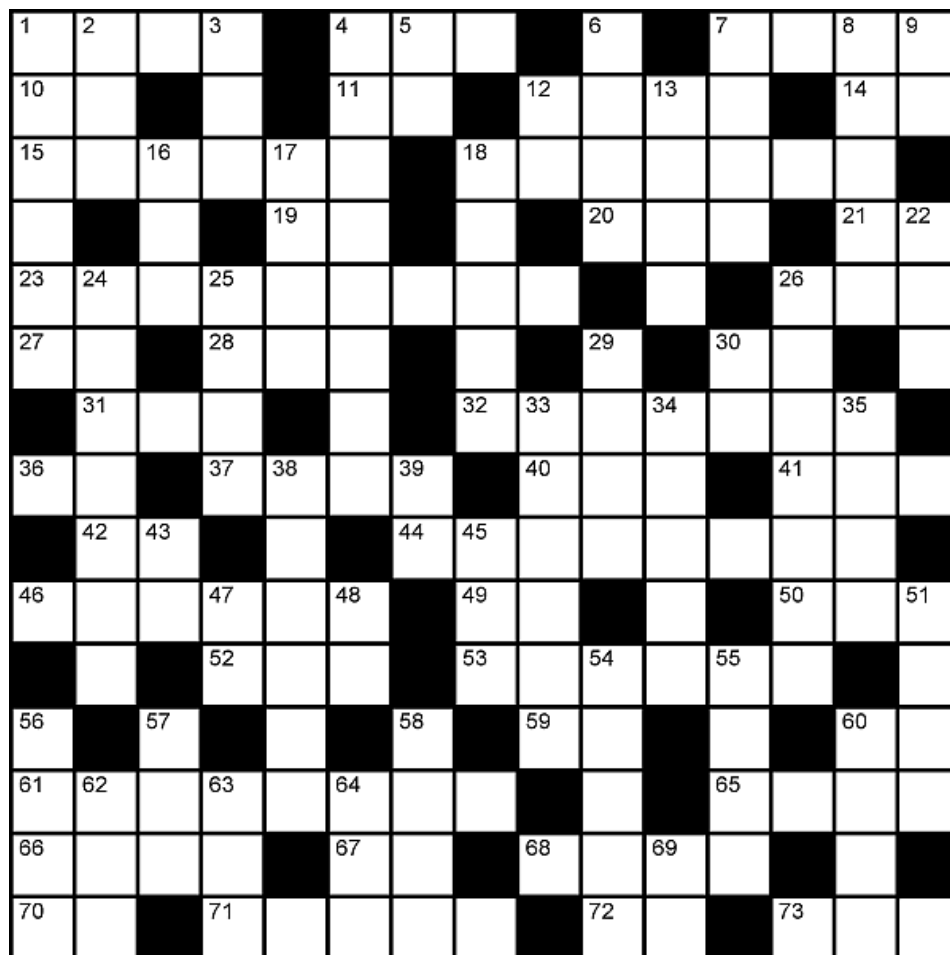

### Across

- 1. What falls on guy wires
- 4. Burp from the sun
- 7. Unit of length
- 10. Not centered (abbr)
- 11. Made it yourself (abbr)
- 12. A type of 1 Across
- 14. Prefix meaning "not"
- 15. Type of hot matter
- 18. The guy that brings the electricity back

- 19. What the user uses (abbr)
- 20. Equipment that doesn't work when you get it
- 21. Send a copy to (abbr)
- 23. Strike from the sky
- 26. Manages ARES in an ARRL section
- 27. Makes "R" in Morse (two letters)
- 28. Chain of ham radio stores (initials)
- 30. Abbreviation for 7 Across
- 31. Question mark prosign
- 32. NOAA weather monitor organization
- 36. Home to the Great Salt Lake (postal code)

- 37. Air pressure has these as well as highs
- 40. Tax-free savings account
- 41. Electric animal
- 42. Not out
- 44. To add notes and discussion
- 46. Tuned hollow enclosure
- 49. Number of words in radiogram text (abbr)
- 50. Time zone in Chicago during the summer (abbr)
- 52. Patches a roof
- 53. Look for
- 59. Tends to the injured (abbr)
- 60. Number (abbr)
- 61. Task left undone (two words)
- 65. Precipitation
- 66. Assistant
- 67. Output power (abbr)
- 68. Sudden peak in wind speed
- 70. Subaudible tone (abbr)
- 71. After freezing
- 72. Local ARES leader
- 73. Makes nests in towers and stings climbers

- 43. Home to Las Vegas (postal code)
- 45. Station that runs a net (abbr)
- 47. Work .. first, worry later
- 48. 365 days (abbr)
- 51. Ripped
- 54. Dispute loudly
- 55. Citizen volunteer response organization
- 56. A sound of thunder
- 57. Change or redesign (abbr)
- 58. Frozen 65 Across
- 60. The weather for antenna work
- 62. Lubricating liquid
- 63. A complete range of similar tools
- 64. ARRL section for Philadelphia
- 69. Between NC and GA (postal code)

**Down**

- 1. Push over
- 2. The three primary electronic components (abbr)
- 3. Type of guy wire
- 4. Used to remove 1 Across
- 5. Postal code for VE4
- 6. Moving air
- 7. Government emergency agency
- 8. Unit of weight
- 9. Home to Nashville (postal code)
- 12. Inductive reactance over 2 x freq x inductance
- 13. Glowing gas used in lights and signs
- 16. Average (abbr)
- 17. Cut off audio
- 18. These carry electricity
- 22. Opposite of CW
- 24. First instance
- 25. Falling ice balls
- 26. Make longer by pulling
- 29. One who enjoys fire (slang)
- 30. Comes before la-la-la-la
- 33. How copperweld seems to always be
- 34. Makes dirt into mud
- 35. To require something
- 38. Absence of service
- 39. Continent attached to NA

Answer to last crossword puzzle.

1	F	2	A		3	A	T	4	O	5	M		6	L	7	I	8	H	9	T		10	M
11	U	T	12	C				13	M	A	S	E	R				14	T	U	B	E		
15	S	U	P	16	E	R			X				17	A	S					N			S
	I		18	S	M			19	S	W	20	A	P			21	B	22	O	N	23	D	S
24	O	25	D		I			26	M	E	G			27	K	E	Y	E	R				
28	N	E	U	T	29	R	A	L			30	C	A	T				31	L	A	32	P	
		M				A			33	L	34	E	O			A					35	M	A
36	D	O	37	P	I	N	38	G			39	E	S	40	D			41	W	42	E	A	R
			H			43	O	44	S			45	M	E	T	A	L						T
46	P	H	O	T	O			O				47	I	B		V				48	P	I	
L		N			49	M	50	O	L	51	E	C	U	52	L	E			53	L	C		
54	A	55	H	O	56	Y		57	M	I	X			58	G	A			59	E			L
60	S	E			61	B	62	E	N	D			63	P		64	S	P	A	65	C	E	
66	M	A	67	X		68	X	I			69	W	I	70	D	E			71	S	O	S	
72	A	L	P	H	A						73	E	N	E	R	G	Y						

Printed Courtesy of ARRL

In the grid-neutralized circuit of Fig. 27 G, the rise and fall of the plate potential is transferred by the neutralizing condenser  $C_n$  through the grid coil, to counteract the voltage changes transferred by direct capacitive coupling inside the tube from plate to grid. In general, grid neutralization is less satisfactory than plate neutralization.

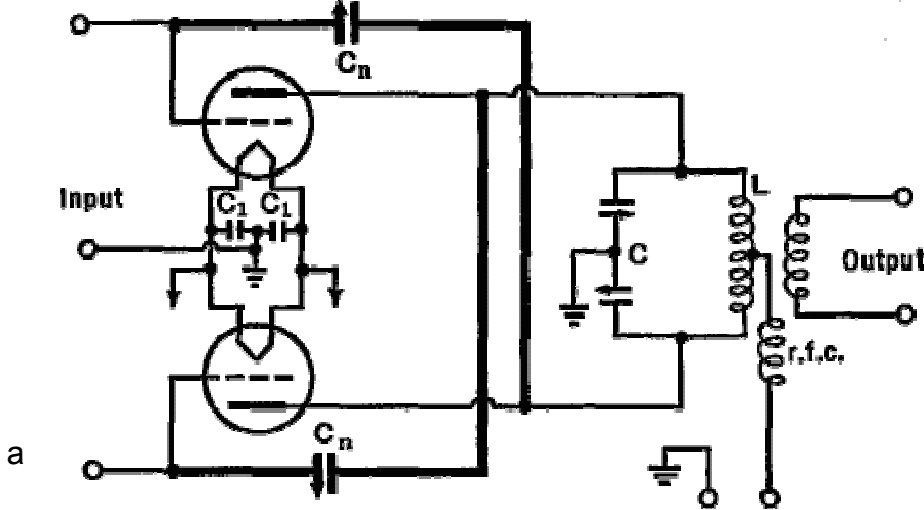

Figure 27 H shows an inductive-neutralization circuit, whereby "link coupling" is used between the grid and plate circuits. This type of neutralization is also complete at only one frequency.

Fig. 27 H. Inductive neutralization of r.f. amplifier

Two condensers ( $C_n$ ) are needed

to neutralize a push-pull circuit, as in Fig. 27 I. The capacitances of the two condensers are nearly equal to each other and to the tube's grid-plate value. When the tubes are electrically identical and the circuits are laid out symmetrically, neutralization can be complete and also be independent of frequency. At the very high frequencies, push-pull circuits are the only type which can be satisfactorily neutralized.

In order to neutralize an amplifier, the filament is heated and r.f. is applied to the input terminals. The plate voltage is to be zero. A d.c. milliammeter is connected in series with the C-bias circuit. The plate tank circuit is tuned back and forth through resonance and  $C_n$  is adjusted until the d.c. grid current no longer changes, or, at most, shows a small gradual rise and fall, with a maximum at resonance. The circuit is then neutralized

### The Larkfield Amateur Radio Club

#### Operates:

#### WR2ABA HUNTINGTON REPEATERS

##### 2 meters

147.210 MHz out/147.810 MHz in  
4z/136.5 Hz PL

##### Linked cross-band with

##### 70 centimeters

448.675 MHz out/443.675 MHz in  
114.8 Hz PL

See Packet Stations on page 7

#### W2LRC SMITHTOWN REPEATERS

##### 2 meters

145.430 MHz out/144.830 MHz in  
4z/136.5 Hz PL

##### 1.25 meters

224.620 MHz out/223.020 MHz in

##### 70 centimeters

448.425 MHz out/443.425 MHz in

These 3 repeaters are linked cross band

#### Members of the Larkfield Amateur Radio Club are invited to use the W2RGM Repeater System:

##### 2 meters

147.075 MHz out/147.675 MHz in  
1.25 meters

224.560 MHz out 222.960 MHz in  
70 centimeters

448.525 MHz out 443.525 MHz in  
114.8 Hz PL

#### These machines are linked cross band also

448.500 MHz out 443.500 MHz in  
448.475 MHz out 443.475 MHz in

The Larkfield Amateur Radio Club  
 Affiliated with American Radio Relay League

**Officers (one year terms)**

President open  
 Vice-president open  
 Secretary Howard Stern KC2OJO (2010)  
 Treasurer Roger Rapp W2GLE (2010)

**General Directors (two year terms)**

Ed Ebert KC2E (2009-2010)  
 Pat McPartland WS2A (2009-2010)  
 Chuck Hartley N2JIY (2009-2010)  
 Daniel Harris KC2TFS (2010-2011)  
 Fred Kruger K2LDC (2010-2011)  
 Gary McDowell K2TVN (2010-2011)

WA2PNU Station Trustee Roger Rapp W2GLE  
 WR2ABA Station Trustee Roger Rapp W2GLE  
 W2LRC Station Trustee Roger Rapp W2GLE

**LARC Birthday List**

Call	Name	Birthday
N2NHA	Bruce A. Anspach	3/31
KC2JDY	Kenneth Cooperstein	3/24
N2UQQ	Richard J. Dufner	3/2
N2AH	Arthur P. Harris	3/11
N2JIY	Chuck Hartley	3/11
AB2NJ	Briggs Longbothum	3/25
WS2A	Patrick McPartland	3/20

**Total: 7**

If you are reading this on a computer let us know so that we may take you off the mailing list. The latest QSX is always available through a link sent out monthly via the Reflector or anytime you visit the club's website at [www.larkfield.org](http://www.larkfield.org).

**Packet Radio Assignment**

WA2PNU (0-15)	145.070	BBS; FlexNet Gateway
WA2PNU-4	145.070	Local area PBBS
W2SWR-1	144.090	Keyboard
KB2JOE-4	144.070	Mailbox
KC2UCD (0-7)	144.900	BBS; FlexNet Gateway
KC2UCD-2 *	144.900	Digi and Keybd SMTARES
KC2UCD-9 *	144.900	SMTARES Mailbox
KC2UCD-10*	145.900	Winlink RMS Portal
KC2CD-15*	144.900	Digi; Keybd; Smithwn EOC

\* Will QSY to 144.93 in the near future

**General Meetings**

January 14, 2010	June 10, 2010
February 11, 2010	September 16, 2010
March 11, 2010	October 14, 2010
April 8, 2010	November 18, 2010
May 13, 2010	December 9, 2010

**Board Meeting**

January 14, 2010	June 10, 2010
February 11, 2010	September 16, 2010
March 11, 2010	October 14, 2010
April 8, 2010	November 18, 2010
May 13, 2010	December 9, 2010

**GOOD AND WELFARE**

**Attention members:** Our Good and Welfare Chairperson is Helene Lazarus (XYL of Arnie N2PLS). Please inform her (499-2837) of news about club members so she may make submissions to this publication.

**ARES/RACES NET**

**Attention to all members:** The weekly ARES/RACES net is active, meeting every Monday evening at 2030 on 147.210. Check in with our net control, John Allocca WB2LUA, to learn of any ARES/RACES news and to help maintain your proficiency in emergency communications procedures.

---

**VE SESSION SATURDAY April 10th  
HUNTINGTON TOWN HALL  
100 MAIN ST., ROOM 114  
WALK-Ins WELCOME**

Team Liaison is Ed KC2E. Contact is Stan N2YKT. Fee is \$15. All elements will be offered and exams start at 9:00AM.

Must have 2 forms of ID, one of which includes a photo. If upgrading, bring an original and a copy of your license and an original of any CSCEs.

**Next General meeting will be on Thursday,  
March 11th at 7:30PM**

**Next Executive Board meeting will be on  
Thursday March 11th at 7:00 PM**

**2010 DUES SCHEDULE**

**Regular Membership: \$25.00**

**Extra Family Member - Same Address: \$6.25**

**Senior Membership, 65+: \$18.75**

**Student Membership: \$6.25**

**Living Outside Club's Operating Sphere: \$6.25**

**PLUS \$5.00 TO GET QSOX VIA U.S. MAIL**

**Make your check payable to:  
Larkfield Amateur Radio Club Inc.**

**And Mail to:  
Larkfield Amateur Radio Club Inc.  
PO Box 1450  
Huntington, NY 11743**

---

**Larkfield Amateur Radio Club, Inc.  
Post Office Box 1450  
Huntington, NY 11743**